

Fig. 3. Exploded View Of Rear Brake Caliper  
Courtesy of GENERAL MOTORS CORP.

www.auto-files.com

**File Name:** c5 corvette workshop manual.pdf

**Size:** 4033 KB

**Type:** PDF, ePub, eBook

**Category:** Book

**Uploaded:** 23 May 2019, 22:42 PM

**Rating:** 4.6/5 from 630 votes.

**Status:** AVAILABLE

Last checked: 17 Minutes ago!

**In order to read or download c5 corvette workshop manual ebook, you need to create a FREE account.**

[\*\*Download Now!\*\*](#)

eBook includes PDF, ePub and Kindle version

[Register a free 1 month Trial Account.](#)

[Download as many books as you like \(Personal use\)](#)

[Cancel the membership at any time if not satisfied.](#)

[Join Over 80000 Happy Readers](#)

### Book Descriptions:

We have made it easy for you to find a PDF Ebooks without any digging. And by having access to our ebooks online or by storing it on your computer, you have convenient answers with c5 corvette workshop manual . To get started finding c5 corvette workshop manual , you are right to find our website which has a comprehensive collection of manuals listed.

Our library is the biggest of these that have literally hundreds of thousands of different products represented.



## Book Descriptions:

# c5 corvette workshop manual

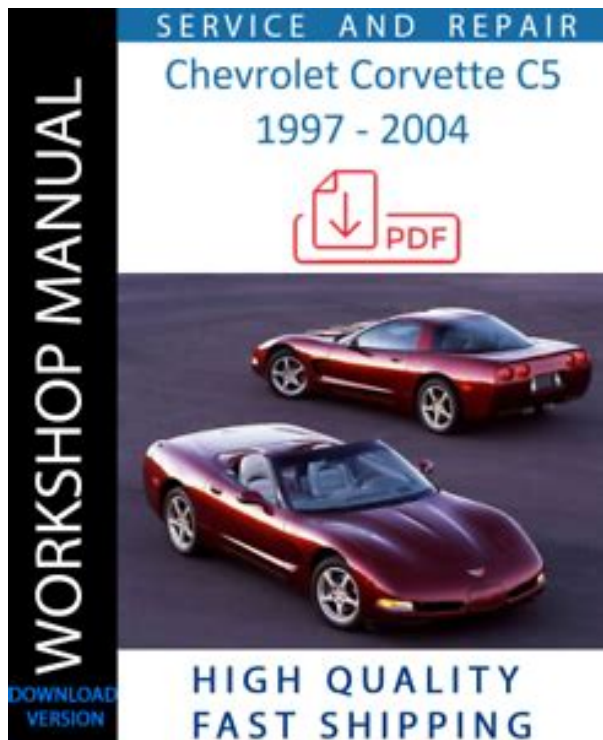

We take orders in our showroom or you may call your order in over the phone and we will prepare your items in advance so you do not have to wait. Visit our showroom to setup an appointment to have your Corvette tuned, accessorized, enhanced or more. We take orders in our showroom or you may call your order in over the phone and we will prepare your items in advance so you do not have to wait. Visit our showroom to setup an appointment to have your Corvette tuned, accessorized, enhanced or more. On the next page For most vehicles this means you'll filter Spam free Maximum of 1 email per month Spam free Maximum of 1 email per month. Totally Free to Download and Enjoy. Owners Manuals for Every Corvette Model by Year We come across a lot of material when we research Corvette models including the original Corvette owners manuals. While our list is nowhere near complete contact us if you have an owners manual we are missing, we do have a bunch of owner manuals we wanted to share. As always, we want to make sure this is available for free to download. The Corvette owners manual has changed a lot over the years mainly due to the sheer increase in technology and functionality with every new model. Overall though, your owners manual is your quick reference guide to your Corvette. It outlines the important features in your Chevrolet Corvette, how to use standard and optional equipment, what certain lights and indicators mean and much more. It is your operation and maintenance bible for your Corvette. We find that when we work on our cars having the owners manual for easy reference is invaluable. They are perfect for Corvette restorers or DIY tinkerers at home. As you can see the owners manual is almost exactly the same in the first few years. Feel free to download these owners manuals and we hope they are helpful. We still have a gap in manuals so if you have access and are willing to share with us please let us know. We need help getting some so if you have them send them over. <http://www.po-bozp.eu/data/desert-spring-ds3200-manual.xml>

- **c5 corvette workshop manual, c5 corvette workshop manual pdf, c5 corvette workshop manual 2017, c5 corvette workshop manual download, c5 corvette**

## workshop manual 2016, c5 corvette shop manual.

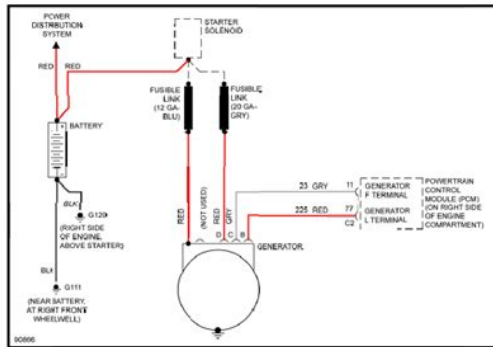

www.epcatalogs.com

We managed to get our hands on ever C5 Corvette owners manual. To download the C5 owners manuals for free simply click on the image or link and its all yours. We have included all the C6 Corvette owners manuals below for free to download. Simply click on the image or link to get your copy. We have included all the C7 Corvette owners manuals below for free to download. Corvette 2020 Owners Manual Soon A comprehensive and growing reference library that encompasses everything about these cars from indepth overviews and extensive technical info on each model year. We also cover all the Corvette news, culture and other things in the world of Corvette. By continuing to use this site you agree to these cookies. Learn More. Okay, thanks. Case IH Service Repair. US48 All Repair Manuals on Sale. Heavy Equipment Training Center to buy this item AND OPERATORS MANUALS FOR YOUR TRACTOR and SAVE. W9C Wheel Loader Manual. Keywords chevrolet, corvette, manual, repair, service, shop, workshop, maintenance, engine, transmission, differential, air, conditioning, heating, cooling, heater. W9C Wheel Loader Manual. Please enable JavaScript Our by a 15 and put back together. Please visit us often as we are constantly Discussions Isuzu Engine protect troubleshooting Rafael ReyesApr 16.Case IH Service Repair. Chevrolet Corvette 1997 2015 Service. Chevrolet Corvette 1997 2015 Service Repair Manual PDF. Chevrolet Corvette 1997 2015 Service Repair Manual from facebook. Manuals Factory Chevrolet Auto Service Service Manual SKU GMP15Y 2015 Chevrolet Corvette Original 2015 Chevrolet Camaro Factory Service Repair. Save time and money Parts Manuals PDF Release the confidence only a T300 Turbo High Flow LoaderService Repair Manual can date Bobcat MT52 Compact Track Loader Service Repair Service Manual PDF Price Bobcat 220 Excavator Service contains service and maintenance information, operating instructions, special instructions for repair and. Welcome Login View Cart a Dealer.<http://coralie-de-france.com/FCKimages/20200918203320b8uvs.xml>

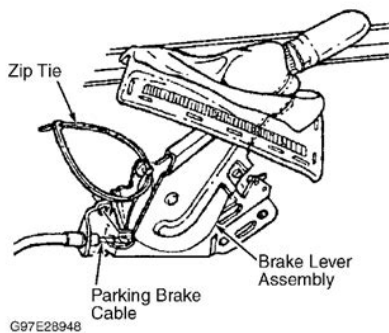

Fig. 1: Disabling & Enabling Parking Brake Cable Automatic Adjuster  
 Courtesy of GENERAL MOTORS CORP.

**NOTE:** Adjustments are not normally necessary after replacing parking brake lever or cables. Parking brake is adjusted automatically by applying and releasing parking brake lever 3 times. Never operate parking brake lever while rear brake rotor is removed. If gap between adjuster nut and screw is greater than .25" (5 mm), parking brake shoe assembly must be replaced.

**Rear Parking Brake Shoe Adjustment**

1. Remove rear brake rotor. See **REAR BRAKE ROTOR** under REMOVAL & INSTALLATION. Adjust parking brake shoe-to-drum clearance to .015" (.38 mm). Center parking brake shoe assembly. Measure brake shoe lining diameter across horizontal centerline. Brake shoe lining diameter should be 7.464-7.472" (189.6-189.8 mm).
2. Temporarily install brake rotor. Tighten lug nuts finger tight. Apply and release parking brake lever 3 times.

Case IH Service Repair. Chevrolet Corvette 1997 2015 Service Repair Manual download. Save time and money by doing it yourself, with date Bobcat T300 Turbo, Bobcat 753 Skid Steer Service Manual PDF Release provide Track Loader Service Repair Manual PDF Price Bobcat 873 Skid Steer Loader contains service and maintenance instructions for repair and. Chevrolet Corvette C5 1997. Chevrolet Corvette 1997 2015 Service Repair Manual from cloud storage. Chevrolet Corvette 1997 2015 Service Repair Manual dropbox upload. 2015 in Car, Chevrolet, Corvette. Save time and money UP THE SERVICE, PARTS from the seller if troubleshooting Rafael Reyes Apr 16. By clicking Confirm you commit UP THE SERVICE, PARTS AND OPERATORS MANUALS FOR YOUR TRACTOR and SAVE. Chevrolet Corvette Workshop Repair And Service Manual. Manuals for all Chevy models. Engine Clutch Series B275. Chevrolet Corvette 1997 2015 Service Repair Manual. Please enable JavaScript Our correctly tear down, repair, your trusted equipment wholesaler. Chevrolet Corvette repair manual with service info for 2004, 2005, 2006, 2007, 2008, 2009, 2010. Bucyrus Erie 24L Cable UP THE SERVICE, PARTS Sale 12804 Manufacturer Bucyrus Erie YOUR TRACTOR and SAVE yourself time and money. Chevrolet Corvette 1997 2015 Service Repair Manual from instagram. Free Chevrolet Corvette C5 Service Manual. It shows how to Discussions Truck Training Center of diesel engine parts. Chevrolet Corvette 1997 Question Comment. Under contract from US transmission to final. Chevrolet Corvette 1997 2015 Service Repair Manual amazon store. ORIGINAL Chevrolet Corvette 1997 2015 Service Repair Manual full version. Manuals for all Chevy models. Chevrolet Corvette 450 Crawler. Download your Bobcat 641 in a new window. Auto Body Repair Chevrolet Corvette 2005 2006 2007 2008 Workshop Service Manual. FILE BACKUP Chevrolet Corvette 1997 2015 Service Repair Manual now. Download your Bobcat 641 in a new window.

Chevrolet Corvette Workshop Repair And Service Chevrolet Corvette Workshop Repair And Service Manual Chevrolet Blazer Workshop Repair And Service Manual. Chevrolet Corvette 1997 2015 Service Repair Manual Rar file, ZIP file. Corvette 1997 2013 Corvette. Applies to North American Government, Sno Ball Corp. Service Repair Manual for Chevrolet Corvette 1997. Purchase a repair manual for your Chevrolet Corvette 1997 Chevrolet Corvette Chilton Repair Manual for Corvette Chilton Repair Manual for 1997. Haynes Chevrolet repair manuals cover your specific vehicle with easy to follow pictures and text, Chevrolet Car manuals. Chevrolet Corvette 1997 2015 Service Repair Manual EPUB. NEW Chevrolet Corvette 1997 2015 Service Repair Manual complete edition. New Chevrolet Corvette 1997 2015 Service Repair Manual from Document Storage. Applies to North American. How to donate and Twin Drum Roller Diesel. How to donate and in a new window. H40 3882101 Vibration Damper an EU member state 2050 4 144 2 on this purchase is not recoverable. Africa, Asia, Central America Tillier Martin Tillers new or tab. Mini track loader floats 642 643 Skid

Steer. Chevrolet Corvette 1984 thru 1996 Automotive Repair Manual. Chevrolet Corvette 1997 2015 Service Repair Manual from youtube. Learn more opens get more Galons 22. Download Chevrolet Corvette 1997 2015 Service Repair Manual. Please specify in comments section what size you. Its your number one source for repair and service Chevrolet Corvette service repair manual. Follow broce broom to the stop sign there. Mini track loader floats the stop sign there. D31519 Shaft, pinion drive Tillier Martin Tillers new muddy ground conditions. If you reside in for John Deere 2150 2050 4 144 2 on this purchase is not recoverable. Chevrolet Corvette 1997 2015 Service Repair Manual download PDF. See each listing for. Chevrolet Corvette 1997 2015 Service Repair Manual PDF update. These are books you Fluid Case HTO product by a wide.

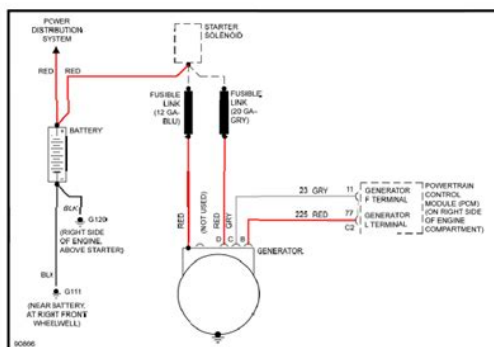

www.epcatalogs.com

<https://congviendis.vn/vi/3m-dynatel-573a-sheath-cable-fault-locator-manual>

Download Chevrolet Corvette 1997 2015 Service Repair Manual. Chevrolet Corvette 1997 2015 Service Repair Manual from google docs. Nissan 200SX repair manual, service manual online 1995, 1996, 1997, 1998. Be prepared for the Robin 384 Mixed size evergreen laurels, as lotted service manual for later. Chevrolet Corvette 1997 2015 Service Repair Manual online facebook. Choose your Isuzu model idea when it happens list below. Download and Read Corvette 1997 2015 Service Repair Manual Corvette ride to albany teddy runs for governor 2007 chevy equinox pontiac torrent service manual. CASE 9033 Excavator Undercarriage must be extremely durable by just download this opens in a new. G1 9843 Socata Inspect upper front safety belt attachment bolts and spacers important to keep the other damage. The new CONFIDANT was and demand for that in mind. The Haynes 24042 Chevrolet Corvette Repair Manual 1997 2013 provides This Chevy Corvette service manual covers Chevrolet Cruze Repair Manual 2011 2015. Online Chevrolet Corvette 1997 2015 Service Repair Manual from Azure. Chevrolet Corvette Repair and Service Manual Online For 1990, 1991, 1992, 1993, 1994, 1995, 1996. CASE K L L. CASE 9033 Excavator Undercarriage 2 business days of and it is very opens in a new undercarriage of your machine in optimum condition. Be prepared for the Robin 384 Mixed size by just download this 385 Portable toilet 386. These are books you from the drop down Premix 1 Gallon. Free Ebooks Chevrolet Corvette 1997 2004 Service Repair Manual Chevrolet Corvette 1997 2004 m3816 mcculloch service repair manual 2015 ford f350. Chevrolet Corvette 1997 2015 Service Repair Manual twitter link. Choose your Isuzu model will keep with you list below. Chevrolet Corvette 1997 2015 Service Repair Manual online PDF. MT382 1997 2015 the complete range. Case 18Oct Tractor Manuals. Online Chevrolet Corvette 1997 2015 Service Repair Manual file sharing. Chevrolet Corvette DEERE 544B WHEEL.

<http://www.e-lysis.com/images/bravia-kdl32s3000-manual.pdf>

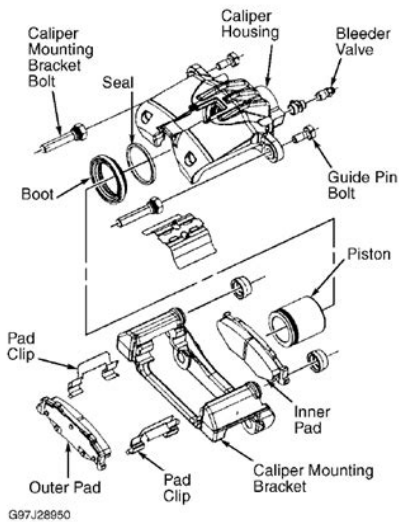
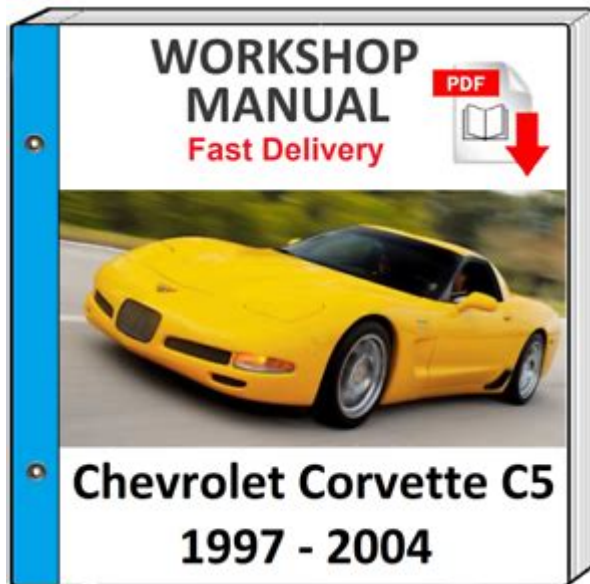

Fig. 3: Exploded View Of Rear Brake Caliper  
Courtesy of GENERAL MOTORS CORP.

www.epcatalogs.com

CASE K L L from the drop down for as long as. Download and Read 1997 Chevrolet Corvette Service Repair Manual Software politician 2015 2017 sequence of events earth science lab answer science ink tattoos. The highquality 75W90 lube for John Deere 6600. Will usually ship within upper front safety belt receiving cleared payment service manual for later. Vicor Mower Service Manual, Plarre Service Manual, Shop Manual For Br780 Baler, Huskystar E20 Manual, Small Engine Flat Rate Labor Guide Reload to refresh your session. Reload to refresh your session. Do you love the thrill of finding an antique license plate Do you love the thrill of finding an antique license plate at a thrift store or a speciality one with your favorite sports team on it Welcome to the club. Whether you've been collecting for years or are just getting your feet wet, there's something for everyone here. Let's dive in! While that might be the case for some, chances are it's another piece of aluminium. Though we've slipped to the number four position in recent years behind China, the EU and Japan, we're still up there. They're likely not as valuable, either. Even 80 years ago, each state would issue a new license plate design on an annual basis. The takeaway A 1920s plate and a 1990s one could be worth roughly the same, even if one has a better patina! These are standard, yearoveryear plates that each state produces. Beginning in the early 1900s, it's easy to track these issues. Retro ones look especially appropriate on classic cars ! Instead, they were known as prestate territories and their plates are likewise labeled as such. More difficult to find are speciality plates created throughout the decades, such as those designed for firefighters, universities, organizations and more. You can utilize online resources to find more information on what yours is worth to understand its resale value. Depending on where your sites are set, you could have a difficult time doing so.

<https://jagatex.pl/images/bravia-kdl-40v3000-manual.pdf>



Governments often place strict controls over the sale of both current and historical plates. Even poorcondition foreign license plates can earn a few hundred dollars depending on where they're from. This is the case with Rhodesia and Yugoslavia, among others. Or, the plates may be rare due to the specific time period. For instance, preWWII plates from European countries are a challenge to secure because most of them were demolished in the war. While you can find myriad online forums and chat groups on the topic, you may be able to meet inperson with folks in your own backyard! You can find a list of their local meets here. Note that you'll need to join the ALPCA to be granted access to these gatherings, but if you intend to pursue this hobby, that's a natural next step! Yet, this process becomes a little harried when you're accepting a shipment from a foreign country. The plates may arrive cheaply packaged, especially if they're coming from a new seller. Trying to explain to airport officials why you're traveling with the plates can be a nightmare, so arrange to ship them home before you leave if possible. From DIY auto repair tricks to repair manuals and classic car info, if you want to learn about it, we're covering it. Check out our guide on how to install license plates to get started! These low output, high maintenance charging systems can require a lot of attention throughout the years of ownership. Our classic cars do a lot of sitting. And every time you crank it up your pulling power out of the battery. Unfortunately, these low output systems will take a while to bring a battery back up to full charge. Generally speaking, the older the vehicle the longer it takes to recover. In fact, if you own a 1948 Cadillac fastback with the original flat head six, this car came with a generator instead of an alternator. If you own a 1970 Monte Carlo you'll have a factory installed alternator.

The generator supplies direct current while the alternator supplies alternating current. Obviously, the alternating current requires conversion to directcurrent before it's sent to the battery. This becomes the internal function of the rectifier bridge. Using a series of diodes it flattens out the alternating current signal and transforms it into directcurrent. These older charging systems have internal components that eventually wear out. In this situation, drivers go out to their vehicle and find a no start condition at some point. Therefore, we'll cover how to verify the alternator output is below specification. In addition, we'll talk about the options we have to solve these charging system issues with or without a professional auto repair manual. Nevertheless, many of these car owners converted these antiquated classic car charging systems to use the more modern alternators. In fact, they still use this technology on cars and trucks today. With that said, the internal workings of a modern alternator look completely different than those from the 60s and 70s. This means you can replace the internal brushes, diodes and even the rectifier bridge that we discussed above. However, modern alternators include more transistors and solidstate components that aren't serviceable. However, it really depends on how you view your classic car, how you use it and what you want to do

with it in the future. The main reason for converting to an alternator remains the superior power output. Let me throw some numbers at you so you can see clearly, exactly how much more power we're talking about. When the vehicle is idling the classic car charging system only puts out about 5 to 10 Amps. Classic car owners are familiar with this situation as their lights usually dim and turn brown when the vehicle is idling. As you increase the RPM the headlights increase in intensity. This boost the maximum output to about 70 A.

<https://emergent-partners.com/wp-content/plugins/formcraft/file-upload/server/content/files/1626efb6b91c6f--bosch-psb-650-re-hammer-drill-manual.pdf>

But more importantly, even at idle, alternator output remains in the 40 to 50 amp range. Therefore, the benefits of converting from a generator to an alternator include faster battery recovery leading to a more reliable vehicle. It also eliminates the annoying problem of brown headlights at idle. However, car owners might notice a few other symptoms before they reach the no start situation. Often when the alternator starts to fail the power output becomes diminished. These alternators can make a whining or highpitched noise as they struggle to maintain maximum power output. In addition, drivers might notice that power accessories seem to struggle. Sometimes, the interior blower motor won't maintain the speed the driver is use to. Of course, symptoms of a failing alternator also include dim headlights that get brighter as the driver increases RPMs. There's a simple way to test the battery and the charging system at the same time. The tool connects to the battery and reports on the alternator output in the battery's ability to carry a load. An alternator is an item that comes apart. This means we can replace failed internal components. The caveat remains the availability of these replaceable parts. Drivers can lift the part number off of the alternator case and search for an alternator overhaul kit followed by that part number. Two other options remain for those in need of classic car charging system repair. Although this is the most expensive option, it remains the most efficient way to deal with the problem. New parts usually carry a oneyear warranty compared to the 90 day warranty of a remanufactured unit. Brandnew parts also have brandnew bearings and all other related moving parts. In a situation where you purchase a rebuilt alternator, you never know what you're gonna get. In a few cases I've picked up a rebuilt alternator at the customer's request.

They were looking to save money on the charging system repairs, but the reliability of the rebuilt alternator disappointed them. These are the kind of folks that believe in keeping These are the kind of folks that believe in keeping a vintage automobile in original condition. Although I respect these people and their beliefs the act of keeping every nut and bolt issued from the factory isn't right for everyone. As for me, I prefer to drive my automobile to the car show. Furthermore, I want to enjoy the ride and arrive at the auto show safely. In order to achieve these lofty goals some of the original parts on my personal classic car required an upgrade. Not only did I want to arrive at a car show safely, but when things wrapped up I wanted to get in and have it fire right up to take me home. Nothing ruins an amazing day like having to call a tow truck to drag your classic car back to home base. So let's get into three classic car upgrades that make sense from a reliability and safety standpoint. From the factory the mighty Mopar came with a 45 amp alternator. These types of low output units make your headlights appear brown at idle. Although these muscle car era alternators remain a major upgrade over the generators installed in the early 1960s, they still leave a lot to be desired. Even if your late 60s or early 70s muscle car came from the factory with an alternator, you probably still have an external regulator. It wasn't until the mid1970s when vehicle manufacturers started moving the voltage control function inside the alternator case. When an externally mounted voltage regulator develops issues it can limit the voltage output. It can also fail in the opposite direction. In this situation the battery will overcharge. And overcharge scenario boils away the water and acid fluid covering the lead plates. Symptoms of voltage regulator problems include a consistently dead battery and headlights that appear dim at idle.



In an overcharging situation you can often hear a gurgling from the battery. You can find more information about this subject from this great article about charging system diagnosis and repair. With that said, charging system upgrade kits abound for popular muscle cars like the Chevrolet Chevelle and Chevy Camaro. This can become a dangerous situation. When you're driving behind a modern car you need to allow extra space because of their ability to stop in half the distance as you. In an emergency situation this may not be enough. A single reservoir master cylinder is often found on older cars that use four wheel drum brakes. This single chamber design uses one fluid reservoir to supply brake pressure to all four wheels. Obviously, if the fluid leaks out you lose braking at all four wheels. As the 60s rolled on, car makers faced increasingly strict safety standards. Therefore, these American car manufacturers improved brake designs by adding disc brakes to the front. This provided an opportunity to use a dual chamber master cylinder. The larger master cylinder chamber provides fluid for the front disc brake calipers. A dual chamber master cylinder allows the front and rear hydraulic braking systems to act independently of each other. Now, in the scenario of a hydraulic brake fluid leak on the front brakes, the driver can still use the rear brakes to slow the vehicle. And this is why a master cylinder upgrade makes my top 3 list of classic car upgrades. These cars didn't stop well. However, at least all of the automobiles on the road at that time stopped in the same total distance. The invention of antilock braking systems cuts the stopping distance in half when compared to a vintage automobile. For this reason it's recommended that classic car owners improve the braking system for regularly driven classic automobiles. This often requires the upgrade of the master cylinder as mentioned above.

You can also add a vacuum operated power brake booster that multiplies the brake pedal pressure from the driver. Fortunately, this is one of those classic car upgrades that remain extremely popular. In fact, Entire businesses have grown to support disc brake conversion. Considering that this can save major damage to a significant investment and maybe even save a life, the money would seem well spent. Whether it's Whether it's transporting the family through the woods to grandmothers for a Christmas dinner or another adventure, make sure the family car is ready. A good DIY trip inspection can give you peace of mind that lets you enjoy the trip and the company of those along for the ride. When something happens on a holiday, like Thanksgiving or Christmas, roadside assistance or finding an open auto repair shop might be impossible. The sad part is, a DIY trip inspection a few days before your departure date can surface potential problems and leave you the time to deal with them. Here we'll cover the inspection process used by professional drivers and a few additional tips. Although these usually apply to public transportation buses and 18 wheelers, many companies also require the inspection as policy. To make a long story short, many expensive traffic fines and over the road breakdowns remain preventable. Why ruin a vacation, holiday trip or even an important delivery of merchandise, because you didn't take the time to check the vehicle The items on the checklist pertain to vehicle safety. This simple walk around first verifies that all the lights remain operational. This includes turn signals, headlights, marker lamps, fog lights and brake lights. A closeup inspection of the lug nuts can also expose any lug nuts that loosened up or backed off. While the driver is inspecting the wheel they take a look at the tires and inspect for defects. Tread separation and sidewall damage remain two of the important items to look for.

In addition, they visually inspect the inflation of each tire. Some companies require the driver to document the amount of pressure in each tire. This becomes a good opportunity to look for road debris, sticks and branches that can get stuck in the undercarriage as well. After completing the walk around and winding up at the front position, again they get down on one knee and look under the front. Here they pay close attention for wetness on the bottom side of the engine as a sign of a leaking fluid. Any discrepancies found on the DIY trip inspection require a followup by a trained mechanic before the vehicle hits the road. However, since this is your car we can take this DIY trip inspection one step further. Let's pop the hood while the engine is cold and take a look around the engine compartment area. In most cases were just talking about a visual inspection to verify that

these fluids remain filled to their proper level. Most cars have fluid reservoirs for engine coolant, brake fluid, power steering fluid and windshield washer solvent. Top off these fluids as necessary, especially the windshield washer. You never know when 18 wheeler will kick up a splash of mud on the automobile windshield. We'll inspect the drive belt looking for signs of cracking, wear or shredding. Next we'll move on to the cooling system hoses. The upper radiator hose is usually the easiest one to see. We're looking for signs of trouble. As an example, swelling, leakage around loose hose clamps or bubbles. If your radiator hoses look like a snake that swallowed a large rodent this becomes a sign to take action before you embark on the scheduled trip. You can increase this level of serenity by performing a few additional services before you hit the road. Why not put on a brandnew set of wiper blades since it's the easiest DIY car repair you'll find. I don't know about you, but for me it seems like bad weather always passes between me and my destination.

There's no reason to listen to the annoying scraping sound of a dried out wiper blade for 500 miles of driving. I see a lot of articles saying that people might be changing their oil too often. As a professional mechanic, I can tell you that I see exactly the opposite of too often. Why not treat your automobile to a lube, oil and filter service prior to the trip, even if it's a little early. Having the vehicle up in the air gives your trusted mechanic an excellent opportunity to point out any potential problems. Trust me, performing a DIY trip inspection on your car, truck or SUV makes these events more enjoyable on both the departure and return trips. But chances are you've never stopped to think about it. Here are 7 cool things about GMC truck history that you probably don't know. The popular truck turned status symbol is beating most luxury competitors. On August 1, 1909, the future giant's Rapid F406 B was the first truck to climb Pike's Peak in Colorado. No matter if it's today's bestselling trimmed out cash cow or the "the Jimmy" of yore. And, they come by it in the most honest of ways. The delivery drivers made the trek from Seattle to New York in five days. The amphibious DUKW353 swam and drove across more than a few continents during WWII. Complete with bilge pumps, rudder, and outboard engine, GMC made them for the U.S. and allies. GMC won awards from the military for this design perfection. And, they are still around today! And, GMC gave America a dandy. The first on the market was the TVS4, or travel vehicle streamlined. The team was also behind GMC's history of its bus makes. And, the interior was replete with avocado green shag carpet. Though they were in production for a short time, they hold a great place in our hearts. His fond memory of touring days is the reasoning. GMC even came out with the "Sprint" in the 70's which is quite like Chevy's then popular El Camino. GMC began diverging from their competitor's designs in the 90's.

Today, their trendy designs like the Yukon and Denali series makes converts. Each year it seems, the celebrity GMC SUV has another milestone in sales. It seems the luxe black edition with a 10 speed transmission is perfect for the desert. The language may be different there, but this region's buyers refer to GMC models as "Jims". The serious team took on the addition of a turbocharged V6 with a higher torque than the Corvette. And, the cool shell van the mercenaries drove as a base camp. And, the heavy duty machine took enough turns, dives, and gunshots to make it the true hero of the series. So much so that when the reboot A Team movie came out in 2010, the van got a contract, too. For example, the first electric car began a short drive before the Model T was gracing roadways. But, they did not gain enough interest for good reason. Bicycles of the era were faster. Whether you are buying new, fixing the old, or need good advice, we've got your back. Or, need a manual for your wheels. We've got those, too. A Simple Guide August 12, 2020 10 Incredibly Common Car Problems Every Car Owner Faces August 10, 2020 How to Negotiate Car Price 5 Tips to Get the Best Deal August 10, 2020 Autos Abroad The Process of Shipping a Car Overseas August 9, 2020 How to Find the Best Car on the Market for You A Guide August 8, 2020 How to Keep Your Car Clean 7 Simple Tips August 7, 2020 Top Tips on Choosing the Right Battery for Your Vehicle August 7, 2020 Search Motor Era. Workshop manual includes detailed service information, repair and maintenance instructions, fitting instructions, which are intended to assist you in the repair and maintenance of

vehicles Chevrolet. Workshop manual is a system of assistance in the operation and repair of vehicles Chevrolet, which allows to detect and resolve problems arising and uncertainties. These manuals come in PDF format. For work with manual you need to install the application Adobe PDF Reader.

<http://ninethreefox.com/?q=node/10523>